

Hot cookline - fridge only

Standard drawer + heat shield top



Applications

- Bulk storage at the point of use in the cookline
- Designed for heavy cooking equipment, mounted on either a Heat Shield or Solid Worktop
- Ideal for meat and fish at the optimum storage temperature for each

Storage Capacity

Gastronorm (GN) Pans
4 x 1/1 GN
100 mm Deep
or equivalent (per Drawer)

Maximum Weight
40 kg of Food (per Drawer)

Volume
86 Litres (per Drawer)

Hydrocarbon R600a Refrigerant

A+ Fridge
Drawer

'A+' Energy Rating
(Consumption 239
kWh/annum)

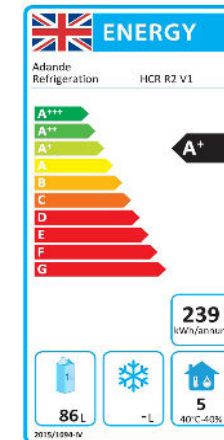

Climate Testing

Tested to **Climate Class 4**
(30°C & 55% relative humidity)
for temperature and energy
consumption and to **Climate
Class 5** (40°C & 40% relative
humidity) for temperature

Electrical

Mains Supply
230 Vac 50 Hz

Power Socket (included)
Correct 2 or 3 Pin Plug
fitted for each country

Mains Lead (included)
2 Metre Coiled Lead

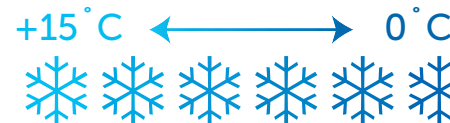

Options

CHEF BASE + HEAT SHIELD (HS)	High castor base (HC)		Standard castor base (C)		Small castor base (SC)		Rollers & feet base (R)		Small rollers & feet base (SR)		Locking roller base (L)		Small locking roller base (SL)	
Finished height	616 mm	HCRI/HCHS	545 mm	HCRI/CHS	524 mm	HCRI/SCHS	501 mm	HCRI/RHS	491 mm	HCRI/SRHS	500 mm	HCRI/LHS	490 mm	HCRI/SLHS
Load-bearing capacity	196 kg		273 kg		498 kg		299 kg		300 kg		272 kg		272 kg	

For full options please see our [Drawer Customising and Accessories](#) pages

Plan View

Chef base
A+ fridge only (HCRI)
With open drawer

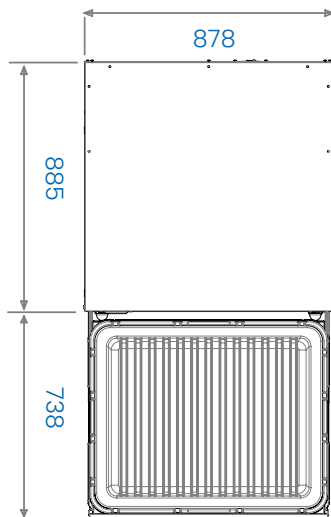

Elevation

Chef base - hot cookline
A+ fridge only (HCRI)
High castors (HC)
Heat shield (HS)
HCRI/HCHS

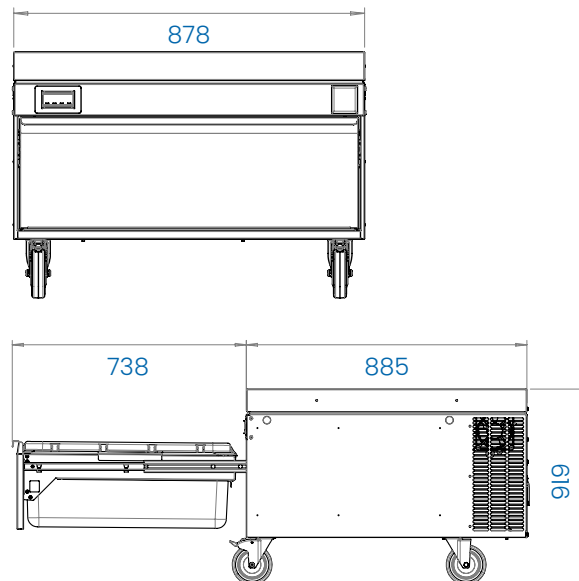

Tops



Drawer Module



Base

