

Bulk storage - fridge only

Standard drawers + cover top



Applications

- Provides back up storage, close to the point of use, for maximum efficiency during busy service periods.
- With our Low Velocity Cooling system, food can be packed into the drawer without leaving any air gaps - there are no 'hot-spots' in an Adande Drawer.
- On request, Adande units can be arranged in mixed configurations, combining Multi-Temperature with Fridge Only Drawer.

Storage Capacity

Gastronorm (GN) Pans
4 x 1/1 GN
100 mm Deep
or equivalent (per Drawer)

Maximum Weight
40 kg of Food (per Drawer)

Volume
86 Litres (per Drawer)

Climate Testing

Tested to **Climate Class 4**
(30°C & 55% relative humidity)
for temperature and energy
consumption and to **Climate
Class 5** (40°C & 40% relative
humidity) for temperature

Hydrocarbon R600a Refrigerant

A+ Fridge
Drawer

'A+' Energy Rating
(Consumption 239
kWh/annum)

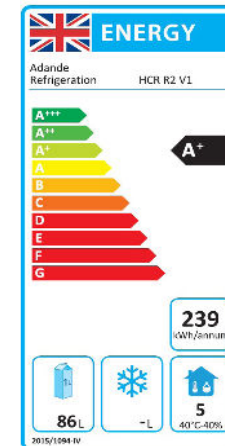

+15 °C ↔ 0 °C



Electrical

Mains Supply
230 Vac 50 Hz

Power Socket (included)
Correct 2 or 3 Pin Plug
fitted for each country

Mains Lead (included)
2 Metre Coiled Lead

Options

STANDARD DEPTH DRAWER UNITS + COVER TOP (T)		Standard castor base (C)		STANDARD DEPTH DRAWER UNITS + SOLID WORKTOP (W)		Standard castor base (C)	
Finished height	1288 mm	HCR3/CT		Finished height	1297 mm	HCR3/CW	
Load-bearing capacity	0 kg			Load-bearing capacity	162 kg		

For full options please see our [Drawer Customising and Accessories](#) pages

Plan View

Bulk storage units
Standard depth drawers (HCR3)
With open drawer

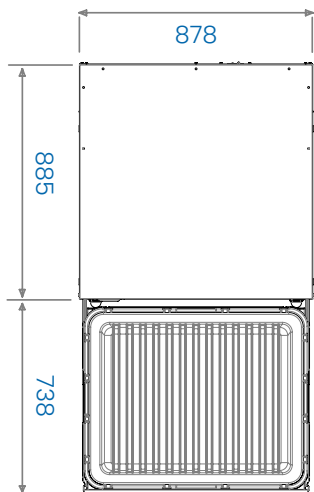

Elevation

Bulk store – standard depth 3 drawer
Fridge only unit (HCR3)
Standard castors (C)
Cover top (T)
HCR3/CT

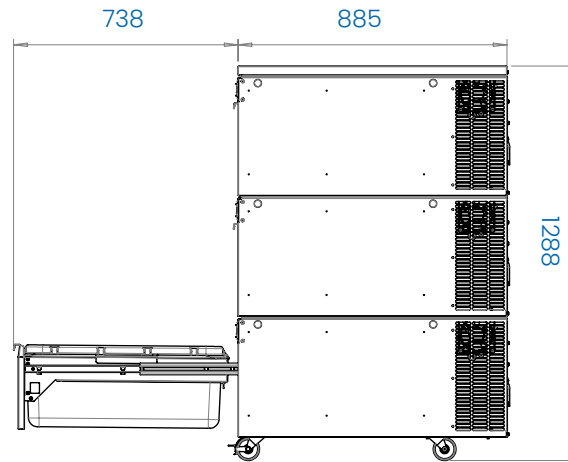
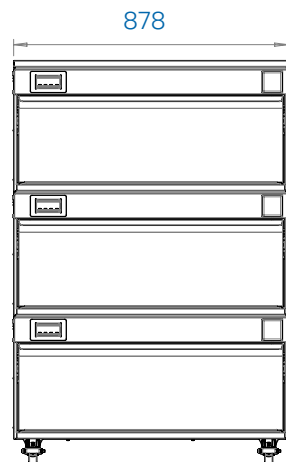

Tops



Three Drawer Module



Base

